

Summary | Statics

Introduction

Centroid / Centre of area

The point where the area of a figure is assumed to be concentrated.

Located on the axes of symmetry.

First moment of area

$$\text{About x-axis} = \int_A y dA$$

$$\text{About y-axis} = \int_A x dA$$

Second moment of area

$$\text{About x-axis} = I_{xx} = I_x = \int_A y^2 dA$$

$$\text{About y-axis} = I_{yy} = I_y = \int_A x^2 dA$$

The product of moment of area about x,y axes

$$I_{xy} = \int_A xy dA$$

The polar moment of area about z axis

$$I_{zz} = J_0 = \int_A r^2 dA = I_{xx} + I_{yy}$$

Radius of gyration

$$\text{About x-axis} = r_x^2 = \frac{I_{xx}}{A}$$

$$\text{About y-axis} = r_y^2 = \frac{I_{yy}}{A}$$

$$\text{About z-axis} = r_z^2 = \frac{I_{zz}}{A}$$

Derived Formulas for Common Shapes

Shape	Description	I_{xx}
Rectangle	Base b . Height h . About centroidal axis parallel to base.	$\frac{bh^3}{12}$
Triangle	Base b . Height h . About base.	$\frac{bh^3}{12}$
Triangle	Base b . Height h . About centroidal axis parallel to base.	$\frac{bh^3}{36}$
Circle	Diameter d . About centroidal axis.	$\frac{\pi d^4}{64}$
Parallelogram	Base b . Height h . About centroidal axis parallel to base.	$\frac{bh^3}{12}$

Parallel Axis Theorem

$$I_x = I_{x_1} + A\bar{y}^2$$

$$I_y = I_{y_1} + A\bar{x}^2$$

$$I_{xy} = I_{x_1y_1} + A\bar{x}\bar{y}$$

Here

- On LHS, the moments of area are about some x , y axes.
- On RHS, the moments of area are about centroidal axes x_1 , y_1 parallel to x , y .
- \bar{x} is the distance between x and x_1 axes.
- \bar{y} is the distance between y and y_1 axes.

Note

I_x is at a minimum when the axis is through the centroid. Same for I_y .

Perpendicular Axis Theorem

$$I_{zz} = I_{xx} + I_{yy} = I_{mm} + I_{nn}$$

x , y , z are a set of axes. m , n , z are another set of axes.

If I_{xx} is at maximum, I_{yy} will be at minimum.

Transformation Law

The 2 sets of axes must share the origin.

Note

Don't have to memorize this. Will be given on exams, if required.

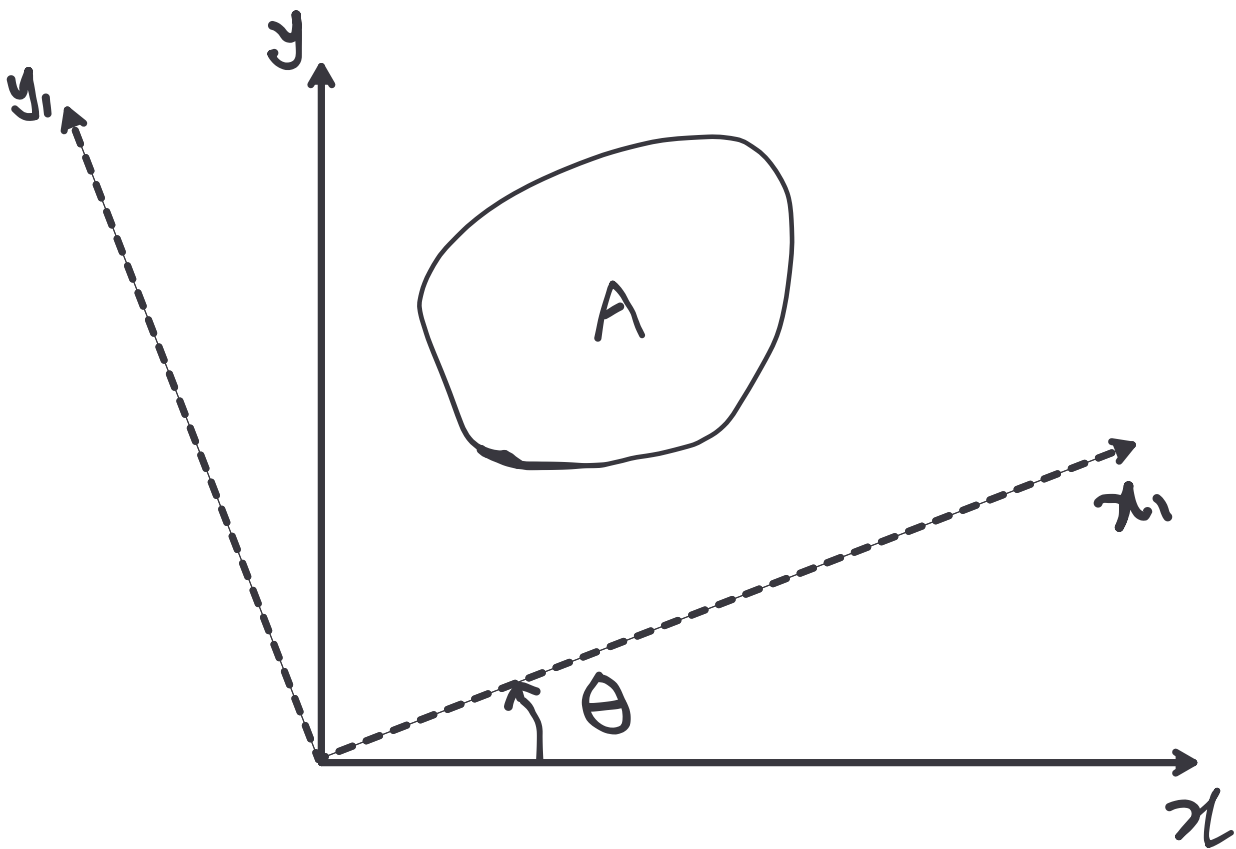

$$I_{x_1x_1} = \frac{I_{xx} + I_{yy}}{2} + \left(\frac{I_{xx} - I_{yy}}{2} \right) \cos 2\theta - I_{xy} \sin 2\theta$$

$$I_{y_1y_1} = \frac{I_{xx} + I_{yy}}{2} - \left(\frac{I_{xx} - I_{yy}}{2} \right) \cos 2\theta + I_{xy} \sin 2\theta$$

$$I_{x_1y_1} = \left(\frac{I_{xx} - I_{yy}}{2} \right) \sin 2\theta + I_{xy} \cos 2\theta$$

Principal Axes

The product of moment of area is zero about principal axes.

$$I_{xy} = 0$$

There will be 2 directions of principal axes which are perpendicular to each other.

Any axis of symmetry is a principal axis.

Principal second moments of area

Second moments about the principal axes.

About principal axes second moments of area will be at minimum and maximum.

Centroidal principal axes

Principal axes through the centroid.

Beams

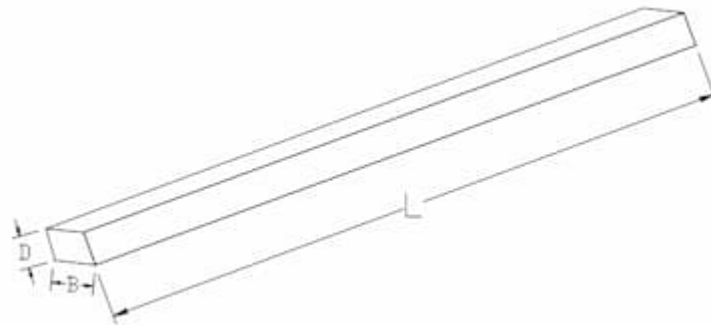

- long ($L \gg B, D$)
- axis of the beam is straight
- constant cross-section throughout its length

Classified by supporting conditions

First 3 are the mandatory ones.

Type	Image
Simply supported beam	A 2D diagram of a horizontal beam. The left end is supported by a pin support, and the right end is supported by a roller support. Two downward-pointing arrows labeled W_1 and W_2 represent point loads applied to the beam.

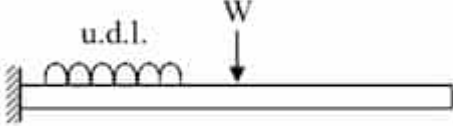
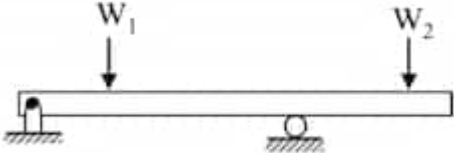
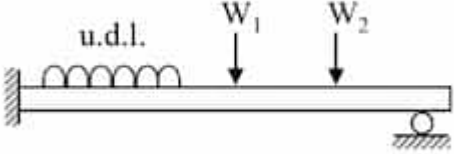
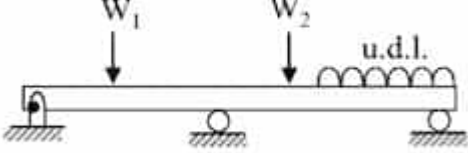
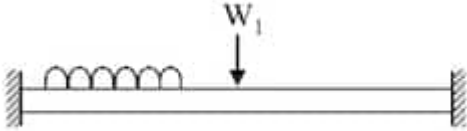
Type	Image
Cantilevered beam	
Overhanging beam	
Propped cantilevered beam	
Continuous beam	
Fixed beam	

At a section

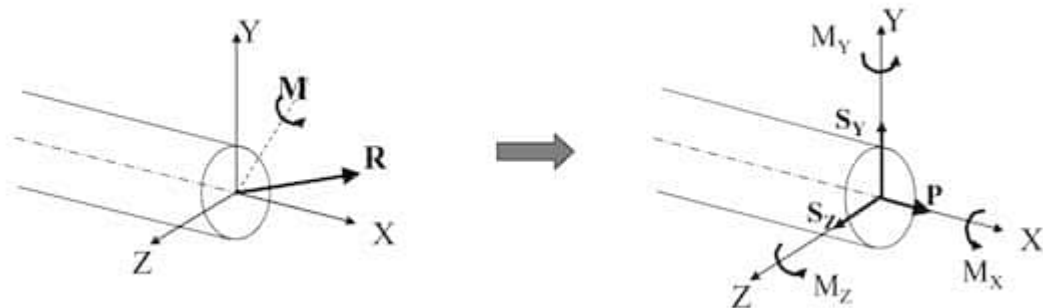

- P - Normal force / Axial force
- S_y, S_z - Shear forces along y and z axis
- M_x - Twisting moment / Torque
- M_y, M_z - Bending moments about y and z axis

Degress of freedom

A plane member have 3 degress of freedom. Any of the 3 can be restrained.

- Displacement in x-direction
- Displacement in y-direction
- Rotation about z-direction

SFD & BMD

Sign convention

- Bending moment
 - Hogging (curves upwards) is **(+)ve**
 - Sagging (curves downwards) is **(-)ve**
- Shear force
 - Clockwise shear is **(+)ve**.
 - Counterclockwise shear is **(-)ve**.

Note

A member is in pure bending when shear force is 0 and bending moment is a constant in a part of a beam.

Distributed load, shear force & bending moment

When a beam is under a distributed load of $w = f(x)$ per unit length.

$$\frac{dS}{dx} = -w$$

$$\frac{dM}{dx} = -S; \frac{d^2M}{dx^2} = w$$

Principle of Superposition

A beam with multiple loads can be split into multiple systems each with a single load. Reason for doing so is the ease of calculations.

Values will be the sum of each system's corresponding value.

Structural Elements

3 types

- Bars (1D)
- Plates and Shells (2D)
- Blocks (3D)

Bar elements are only focused for 1st semester.

Pin Joint

Doesn't exert a moment. Free rotations are allowed. When only pin joints are used, bars will have only axial forces.

Bars

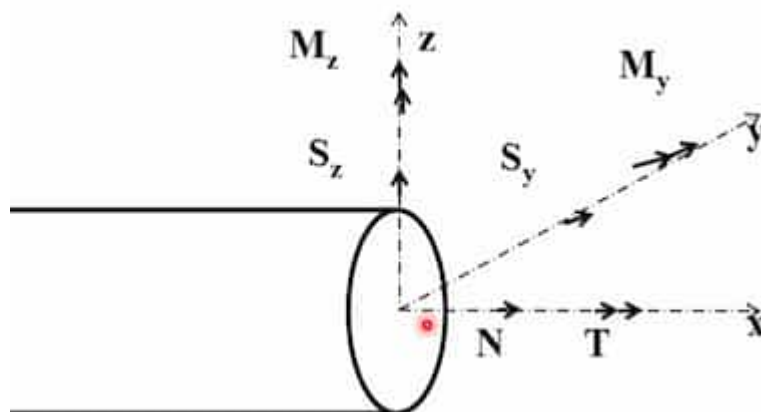

Here

- N - Axial force
- S_x, S_y - Shear force
- M_x

Types of bars

Axially loaded

Generally in trusses, **pin joints** are considered.

- Predominant tension - Ties
- Predominant compression - Struts

Flexural

- Predominant bending - beams

Torsional

- Predominant torque - shafts

Trusses

Also known as Ties-Struts model.

Definition

An assembly of members used to span long distances. Idealized as

- Connected by **frictionless pin joints** at their ends
- Developing axial forces

Types

2 types

- Plane truss (2D)
- Space truss (3D)

A truss requires 3 external reactions for equilibrium.

Predominant force is axial force.

Advantages of truss

- High/length span
- Material efficiency

Triangulation

- Start with a triangle (3 bars and 3 joints)
- Add 2 more bars and a joint repeatedly to create a truss

This type of truss is a **simple truss**.

Simple (Closed) Truss

When a truss is only made of bars and joints.

Open Truss

When a truss is pinned directly to a foundation. It has 1 member & 2 free joints less than a closed truss.

Stability of trusses

When a truss is:

- unstable: it's called a mechanism
- stable: it's called a structure

Stable truss

When the shape cannot be altered, the structure is **internally stable**.

Stable & determinate (simply stiff)

Determinate means internal forces can be determined by laws of statics alone.

Stable & indeterminate

Indeterminate means laws of statics alone are not sufficient to determine forces; relative stiffness of members will influence the solution (Indeterminate trusses are safer)

Unstable truss

When the shape can be altered, the truss is called a mechanism.

Necessary condition for a 2D simple (closed) truss

$m = 2j - 3$ is a necessary but not sufficient condition being simply stiff.

- $m < 2j - 3$ - truss is unstable
- $m = 2j - 3$ - truss is determinate if stable
- $m > 2j - 3$ - truss is indeterminate if stable

Necessary condition for a 2D open truss

$m = 2j$ is a necessary but not sufficient condition being simply stiff.

- $m < 2j$ - truss is unstable
- $m = 2j$ - truss is determinate if stable
- $m > 2j$ - truss is indeterminate if stable

Necessary condition for a 3D simple (closed) truss

$m = 3j - 6$ is a necessary but not sufficient condition for being simply stiff.

Necessary condition for a 3D open truss

$m = 3j$ is a necessary but not sufficient condition for being simply stiff.

Analysis of Trusses

Deviations from the ideal in real trusses.

- Loads are not applied only at joints; hence there is bending in members
- Joints are not perfectly pinned, so moments can be developed at joints

Method of Joints

Principle

Since the truss is in equilibrium, each pin joint must be in equilibrium.

Note

2 equilibrium equations can be written at each joint - vertical & horizontal

Sign convention

Forces acting on each joint is marked. Tensile forces are positive. Compressive forces are negative.

Method

- Find external reactions using equilibrium using equilibrium equations for the entire truss.
- Start with a joint with only 2 unknown joint forces.
- Mark the tensile forces (consider all forces are tensile) acting on the join.
- Find the unknown forces at the selected joint, using 2 equilibrium equations for the joint.
- Go to all other joints in turn and find forces in all the members.

Special cases

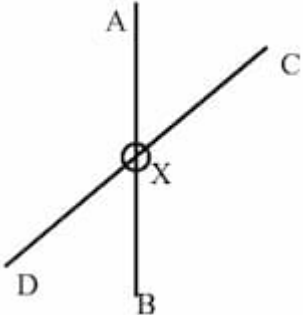
Case	Description
	$F_{AX} = F_{XB} \wedge F_{DX} = F_{XC}$

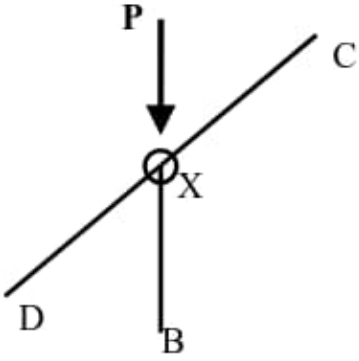
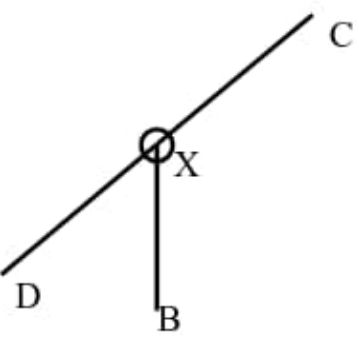
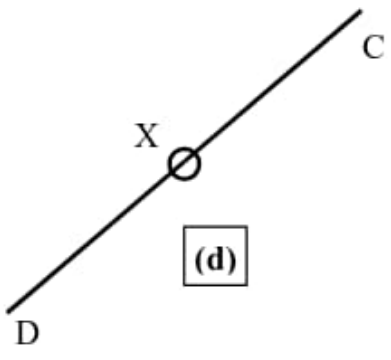
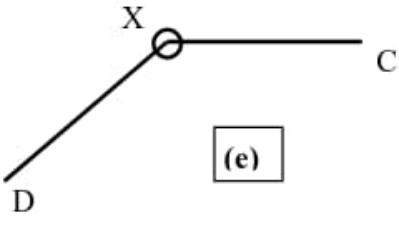
Case	Description
	$F_{AX} = F_{XB} \wedge F_{DX} = F_{XC}$
	$F_{XB} = 0 \wedge F_{DX} = F_{XC}$
	$F_{DX} = F_{XC}$
	$F_{DX} = F_{XC} = 0$

Method of Sections

Principle

Since the truss is in equilibrium, each part of it must be in equilibrium in stable equilibrium.

Method

- Decide on which member's internal force must be calculated.
- Cut the truss through **3 or less** members including the target member.
- Internal forces in cut members become external forces. Can be represented as tensile forces.
- Use equilibrium equations for RHS or LHS section to find the internal forces.

Beam Analogy (Approximate) method

We find the internal forces assuming the elongated truss is a beam.

ⓘ For a simply supported beam

- Maximum bending moment is at mid-span: $M_{\max} = \frac{wL^2}{8}$
- Maximum shear force is at the supports: $\frac{wL}{2}$

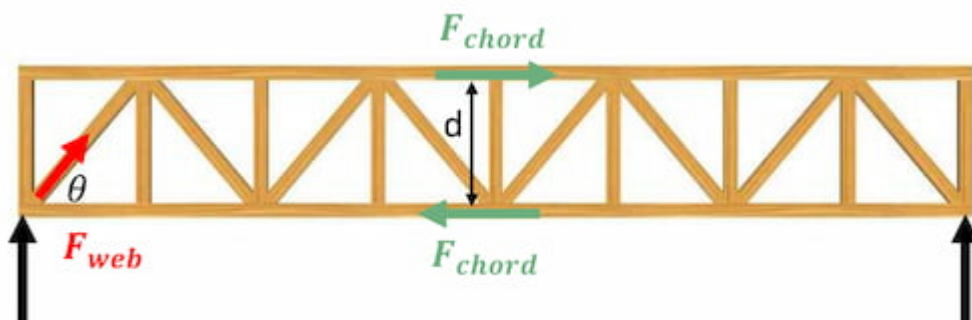

Here:

- Chord members - horizontal members
- Web members - diagonal members
- d - truss depth

In the truss,

- Bending moment is carried by chord members.

$$\text{Bending moment} = F_{\text{chord}} \times d$$

- Shear force is carried by vertical component of web member force

ⓘ Pratt & Howe type trusses

Above-mentioned truss is **Pratt type**. (*is that correct?*)

Howe type truss is a similar structure.

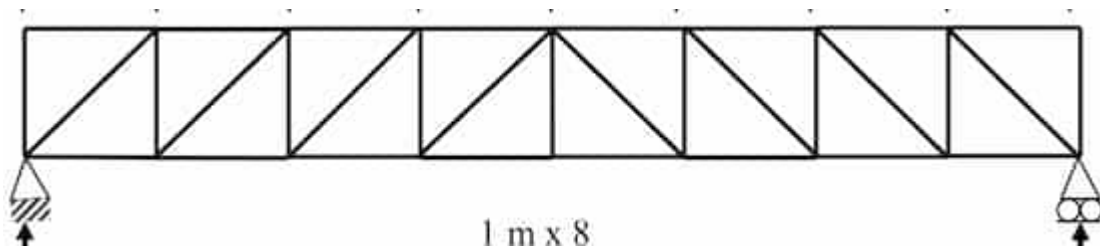

In pratt type truss, internal force in web members are tensile. In howe type trusses, internal force in web members are compressive. Usually **Pratt type** is cost-efficient. To make sure a howe type truss is strong enough like pratt type, web members must be shorter and thicker.

Indeterminate Trusses

When a truss is indeterminate, one or more compatibility equations (related to truss deformation) must be used.