

Mechanical Properties

Introduction

Tensile Force

Pulls out of the cross-sectional area.

In the direction of force, length increases. Cross-sectional area decreases.

Compressive Force

Pushes into the cross-sectional area.

In the direction of force, length decreases. Cross-sectional area increases.

Stress

Force per unit area.

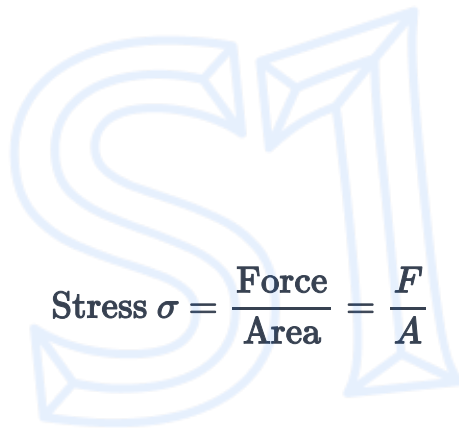

$$\text{Stress } \sigma = \frac{\text{Force}}{\text{Area}} = \frac{F}{A}$$

Engineering stress

$$\text{Engineering stress } \sigma = \frac{\text{Force}}{\text{Initial Area}} = \frac{F}{A_0}$$

True stress

$$\text{True stress } \sigma_T = \frac{\text{Force}}{\text{Instantaneous Area}} = \frac{F}{A_i}$$

Strain

Dimensional change with respect to the original dimensions.

Engineering strain

$$\text{Engineering strain } \epsilon = \frac{\text{Extension}}{\text{Initial Length}} = \frac{l - l_0}{l_0}$$

True strain

$$\text{True strain } \epsilon_T = \ln \frac{l_i}{l_0}$$

Ductility

A measure of the degree of plastic deformation at fracture.

Most metals are ductile. Ductile materials have high tensile strength.

Percentage elongation

$$\frac{l_f - l_0}{l_0} \times 100$$

Percentage reduction in area

$$\frac{A_0 - A_f}{A_0} \times 100$$

Brittle

A material that experiences very little or no plastic deformation.

Brittleness order: Ionic bonds > Covalent bonds > Metallic bonds

Malleability

Ability of a material to undergo plastic deformation under compression.

Note

All ductile materials are malleable. Converse is **not** true.

Ductility & Brittleness

Depends on:

- Composition of the material
- Temperature

Fracture

Separation of a solid into more than 1 parts under load or stress.

Based on the type of load:

- Tensile fracture
- Compressive fracture
- Shear fracture
- Fatigue fracture
- Creep fracture

Characterized into 2:

- Ductile fracture
- Brittle fracture

Ductile fracture

Materials show significant amount of plastic deformation prior to fracture. Fracture surface gives cup & cone appearance. Aka. cup-and-cone fracture.

Steps:

1. Specimen forms a neck
2. Cavities start to form within the neck
3. Cavities join with each other and form a crack
4. Crack propagates towards surface perpendicular to stress
5. Direction of crack changes to 45°

Brittle fracture

Little or no plastic deformation prior to fracture. Fracture surface is smooth.



More dangerous than ductile fracture.

- No warning sign
- Crack propagates at very high speeds
- No need for extra stress during crack propagation

Elasticity

Deformation is temporary. Returns to its original shape when load is released.

Plasticity

Opposite to elasticity. Deformation is permanent.

Linear elastic materials

When elastic deformation portion in stress-strain diagram is a straight line.

Young's modulus

Aka. elastic modulus. Can be thought of as **stiffness**.

$$\text{Young's modulus } E = \frac{\text{stress}}{\text{strain}} = \frac{\sigma}{\epsilon}$$

Nonlinear elastic materials

When elastic deformation portion in stress-strain diagram is not a straight line.

Secant modulus

Equal to the tangent of the line connecting a point in the stress-strain diagram and the origin.

Tangent modulus

Equal to the instantaneous tangent on a point in the stress-strain diagram.

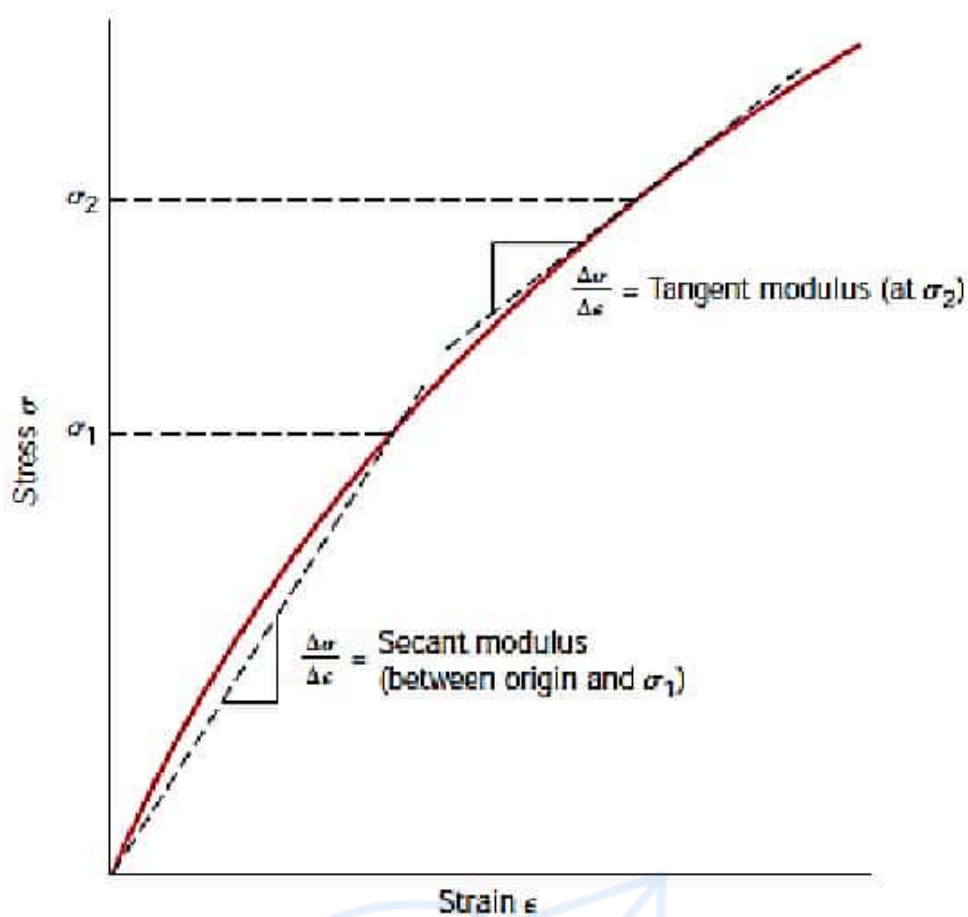

Poisson's ratio

A tensile stress in a particular direction causes extension (say ϵ_z) in that direction and contraction in other two directions (ϵ_x and ϵ_y). For isotropic materials:

$$\nu = -\frac{\epsilon_x}{\epsilon_z} = -\frac{\epsilon_y}{\epsilon_z}$$

For metals (if not given) can be taken as $\nu = 0.34$. Rubber's poisson's ratio is 0.5 which is the maximum possible value, mathematically.

Isotropic materials

Homogenous materials. $\epsilon_x = \epsilon_y$.

Tensile Test

[Stress-strain plot](#) will be produced in the test.

Testing setup

Follows ASTM Standards E 8 and E 8M. (American Society for Testing and Materials).

The specimen:

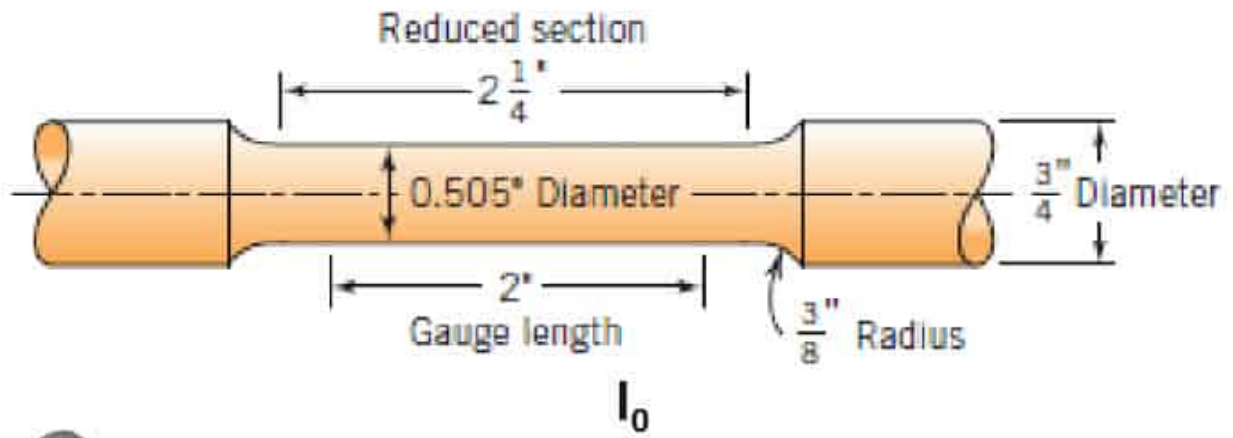

Here

- Gauge length l_0
- Initial diameter d_0
- Initial area $A_0 = \frac{\pi d_0^2}{4}$

The setup:

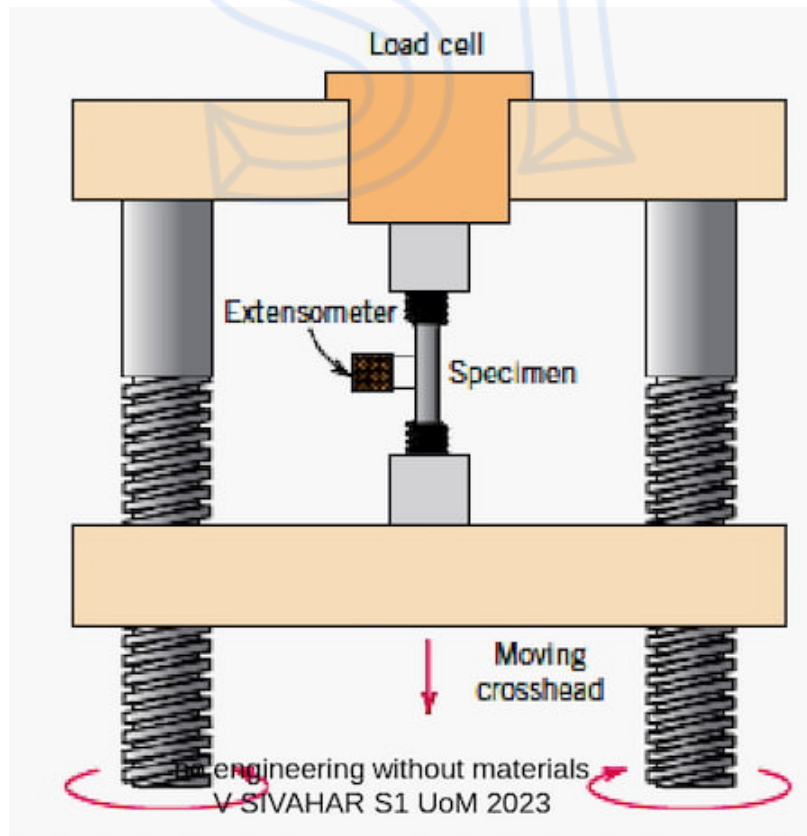

Test will be done until the specimen fractures. Results are converted to engineering stress and strain, and plotted.

Load cell

Measures the force applied to the specimen.

Extensometer

Used to measure the elongation (increase in length) in the specimen.

Necking

All deformation up to the maximum point is uniform throughout the specimen.

At this maximum stress, a neck begins to form – known as necking. All subsequent deformation is confined to this neck.

For brittle material

The σ - ϵ behavior of brittle materials cannot be assessed by a tensile test because:

- Difficult to prepare test specimens
- Difficult to grip brittle materials without fracturing them

Hence, fracture strength is specified for engineering design purposes. Tensile strength is calculated from its **modulus of rupture (MOR)** or **flexural strength** value.

$$\text{Tensile strength} \times 1.3 = \text{MOR}$$

Stress Strain Plot

The below properties can be observed in a stress-strain plot.

- Elastic region
- Yield point
- Proof stress
- Plastic portion - steadily decreasing slope
- Ultimate tensile strength
- Localization of the deformation
- Young's modulus
- Upper and lower yield stresses
- Fractural strength

Yield stress point

The point where plastic deformation starts in stress-strain diagram.

Yield strength

Stress at yield stress point. Denoted by σ_y . Used when the strength of a metal is cited for design purposes.

True yield stress point is very difficult to find practically. Therefore **strain offset method** is used to find an approximate yield strength.

Strain offset method

A straight line is constructed parallel to the elastic portion of the stress-strain curve at some specified strain offset. The stress corresponding to the intersection of this line and the stress-strain curve is defined as the yield strength σ_y .

0.2% proof stress

Yield strength when 0.002 is used in strain offset method.

For steel

Yield strength is taken as the average stress at the lower yield point. Strain offset method is not required. Upper yield point occurs because of C atoms, and is specific to steel.

Observables

Note

After yield point, gradient of the stress-strain curve decreases up to the necking point. This is an indication that the material is becoming stronger and harder.

Ductility

Higher strain at fracture or failure strain.

Implies:

- Greatest percentage elongation

Stiffness

Slope of the elastic region. Steeper line means more stiffness.

Strengthness

- For ductile materials: [yield stress](#)
- For brittle materials: fracture stress

Flexibility

Higher strain in elastic region.

Toughness

Area under the curve, until the breaking point. Higher area means the higher toughness.

Tensile strength

After yielding, the stress necessary to continue plastic deformation increases to a maximum, and then decreases.

Ultimate tensile strength (UTS)

The maximum stress that can be sustained by a material in tension.

$$\text{UTS} = \frac{\text{max load}}{\text{original cross-sectional area}}$$

Necking starts after UTS point.

Flexural Test

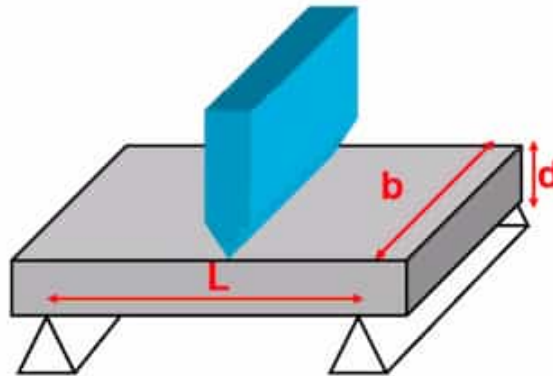

Support the material at 2 ends. Apply pressure perpendicular to the material until the material fractures. 3-point bending is used here.

$$\text{MOR} = \frac{3PL}{2bd^2}$$

Here:

- L - length
- b - width
- d - depth

Ductile-Brittle Transition

Ductile materials show brittle behavior as the temperature is lowered. This is known as ductile-brittle transition.

Ductile-brittle transition behavior of materials is studied by performing impact test over a range of temperatures.

The transition behavior is:

- Sudden in BCC metals (eg: Steel)
- Gradual in FCC metals (eg: Copper)

Ductile-Brittle Transition Temperature

The temperature which a material is:

- brittle below the temperature
- ductile above the temperature

Many steels exhibit this behaviour.

Note

Titanic sunk because of this transition which was unknown at that time.

Work Hardening

Strength and hardness of a metal increases as a result of plastic deformation. This process is called work hardening.

Increases:

- strength
- hardness

Decreases:

- ductility
- toughness



Steps

- Specimen is loaded onto a [tensile test](#) apparatus
- Test is stopped after the specimen has plastically deformed and haven't reached UTS
- Specimen is unloaded and reloaded
- New $\sigma - \epsilon$ diagram will have an increased yield strength

Toughness

Maximum strain energy, a material can absorb upto fracture. Area under the $\sigma - \epsilon$ graph is a measure of toughness. Can be measured by [impact test](#).

Generally ductile materials have a high toughness compared to brittle materials.

Charpy Impact Test

Tester

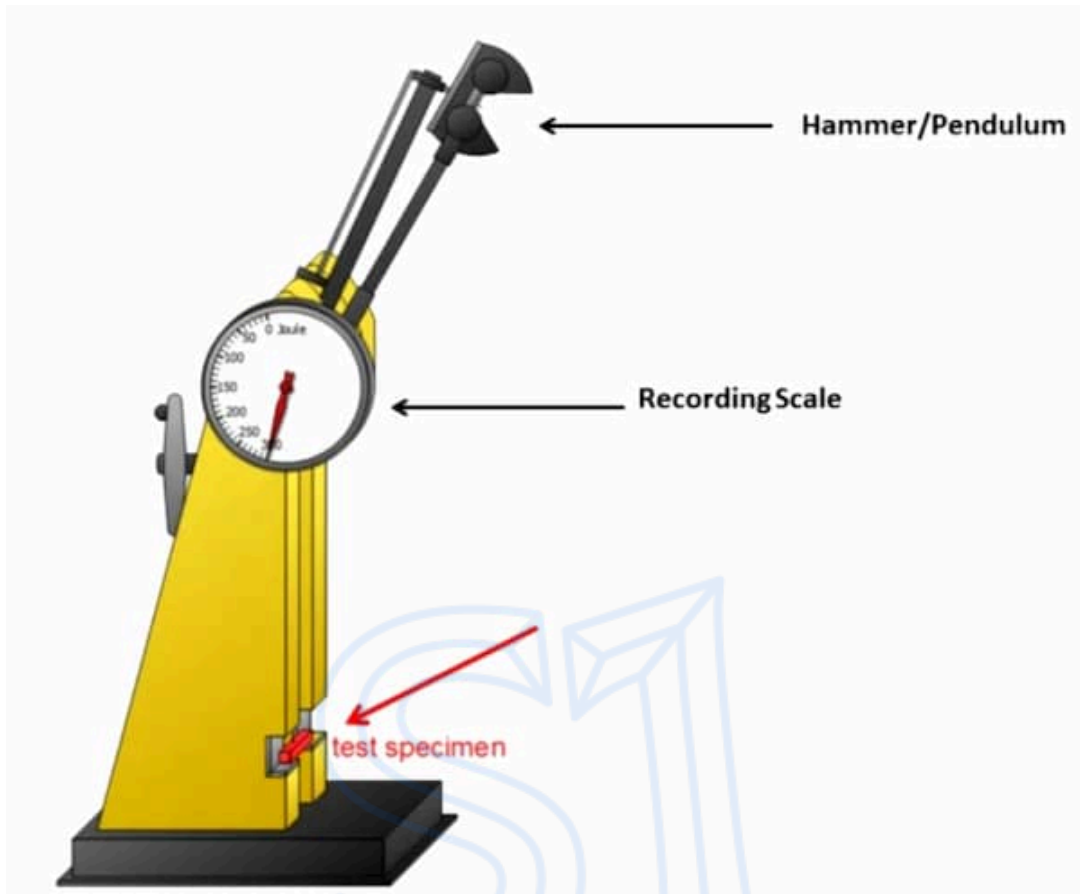

Specimen

According to ASTM-E 23.

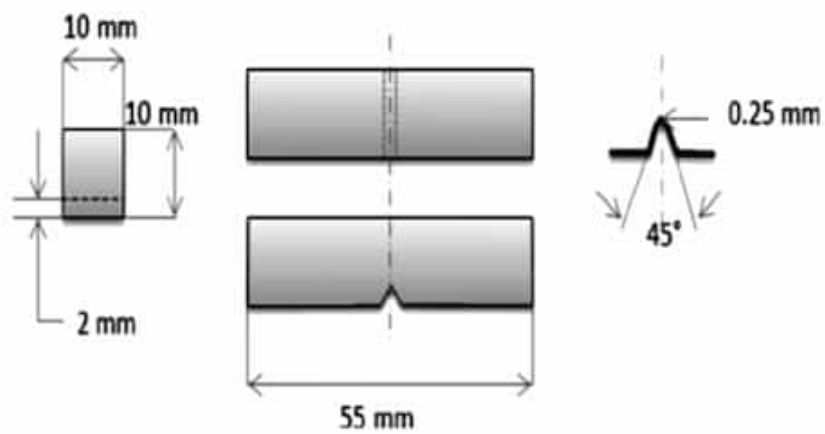

Specimen is notched to keep the crack straight.

Loaded state

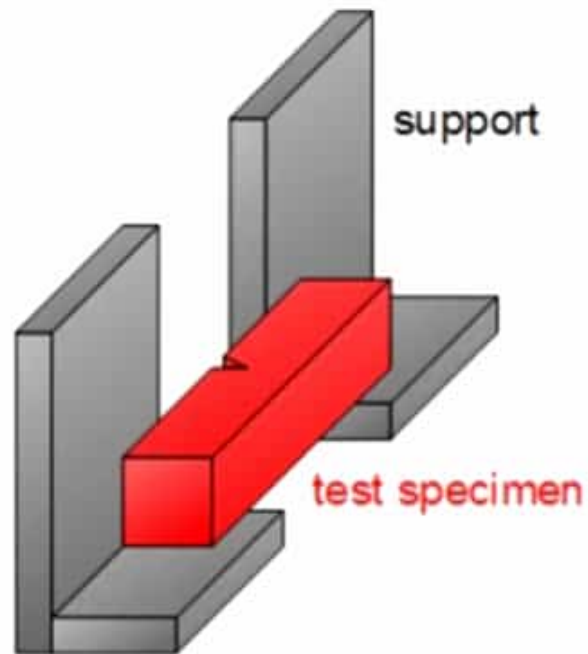

Hardness

Hardness of metals is defined as resistance to indentation. Can be measured by [indentation test](#).

When 2 surfaces are rubbing against each other, hardness is important. Materials with less hardness will be worn off quickly. Only materials with high hardness, can cut through materials with light hardness. Diamond is the hardest material.

Indentation Test

Metal is subjected to indentation with a hard indenter. Depth of the indent is a measure of hardness.

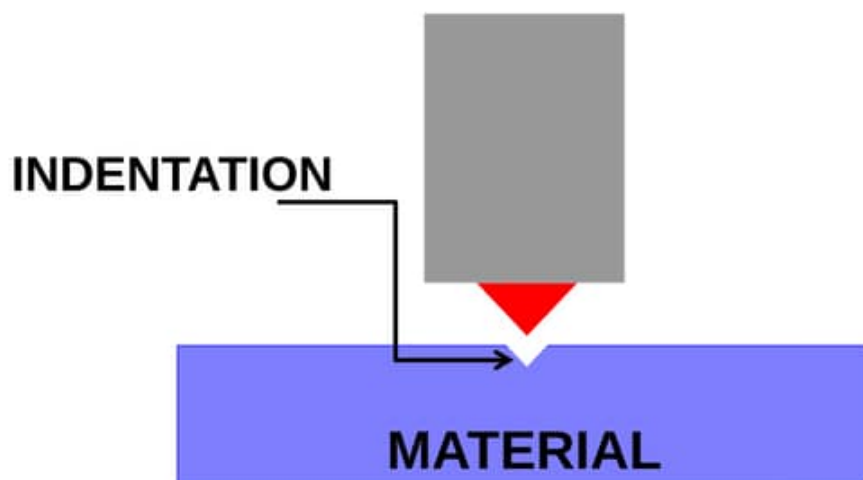

Hardness units differ with the type of indenter used and the load applied.

Units

Brinell (HB)

- 10 **mm** diameter steel / WC ball indenter
- Any load can be applied
- Diameter of the indentation is measured instead of the depth

$$HB = \frac{2F}{\pi Dh}$$

Here:

- F - applied load (in **kN**)
- D - diameter of the indenter (in **mm**)
- d - diameter of the indentation (in **mm**)
- $h = (D - \sqrt{D^2 - d^2})$ - depth of the indentation (in **mm**)

Vickers (HV)

- Pyramid shaped indenter made of diamond
- Any load can be applied
- Diagonal lengths d_1 and d_2 of the diamond-shape indentation are measured
- Average d is used in the calculation

Note

Angle between the diamond faces is **136** degrees.

$$HV = \frac{1.854 F}{d^2}$$

Rockwell (HR)

Not accurate enough to be used in academic level (or where accuracy is important). Industrially preferred because of ease of measurement. Only 3 load options.

Type	Load	Indenter
HRA	60kg	Cone-shaped indenter. Made of diamond.
HRD	100kg	Cone-shaped indenter. Made of diamond.
HRC	150kg	Cone-shaped indenter. Made of diamond.
HRF	60kg	1/16" diameter (1.5mm approx.) ball made of steel
HRB	100kg	1/16" diameter (1.5mm approx.) ball made of steel
HRG	150kg	1/16" diameter (1.5mm approx.) ball made of steel
HRE	100kg	1/8" diameter (3mm approx.) ball

ⓘ Note

No need to remember the above data.

